

# Fox Hunting 101

A practical overview of amateur radio direction finding (ARDF)

Presented to the:  
Amateur Radio Club at KSU



Presented by:

Joe Domaleski, KI4ASK

Mary Catherine Domaleski, KI4HHI

Date: October 12, 2020

# Amateur radio is better in the great outdoors!



# Agenda

- What is fox hunting?
- Why is fox hunting so much fun?
- Why is fox hunting an important skill?
- Basic fox hunting equipment
- Three-step technique for finding the fox
- Step 1 – Finding the signal
- Step 2 – Triangulating the source
- Step 3 – Attenuating the signal and finding the fox
- General fox hunting tips
- Advanced topics for future study
- Suggested resources



# What is fox hunting?

Locating a hidden radio transmitter

- Fun and useful activity that involves finding a hidden radio transmitter
- It's a lot like a scavenger hunt, orienteering, or geocaching involving radios
- Requires simple direction finding equipment
- Easy to learn with just a few basic skills needed
- Is recognized as a competitive sport called ARDF



# Why is fox hunting so much fun?

- Being outdoors enjoying the fresh air and scenery
- The social aspect of working together as a team
- Anyone can participate, it does not require any special type of license
- No special equipment required, a simple radio receiver is sufficient
- The competitiveness of working against other teams
- The satisfaction of putting together and building your equipment
- The physical exercise of walking and searching
- The mental exercise of taking bearings, plotting, and finding the signals



# Why is fox hunting an important skill?

- Search and Rescue
  - Crash sites
  - Stranded people
  - Wildlife beacons
  - Distress signals
- Locating interference
  - Jammers
  - Illegal transmissions
  - Stuck transmitters
  - Sources of noise



# Basic foxhunting equipment



**Fox** – the radio transmitter provided by event organizer



**Sniffer**– the radio receiver used to find the fox



**Antenna** – used to capture or null the radio signal



**Attenuator**– used to decrease signal strength

# Basic foxhunting equipment - Fox

The transmitter (aka “fox”) can come in a wide variety of sizes, power levels, and functions.

Daddy “high power” vs.  
Baby Fox “low power”





# Basic foxhunting equipment – Sniffer (Radio)



- Scanner
- Handi-Talkie (HT)
- Signal strength meter (RSSI)
- BNC connector for quick antenna change



# Basic foxhunting equipment – Antenna



# Basic foxhunting equipment – Yagi Antenna



- Directional antenna
- High gain in front
- Low gain in back
- Almost no gain on sides
- Used to locate the initial signal
- Used to take bearings & triangulate the signal
- Not needed when you're close to the fox
- You can purchase one or make one yourself (what we did)
- The "tape measure" Yagi is a classic fox hunt antenna

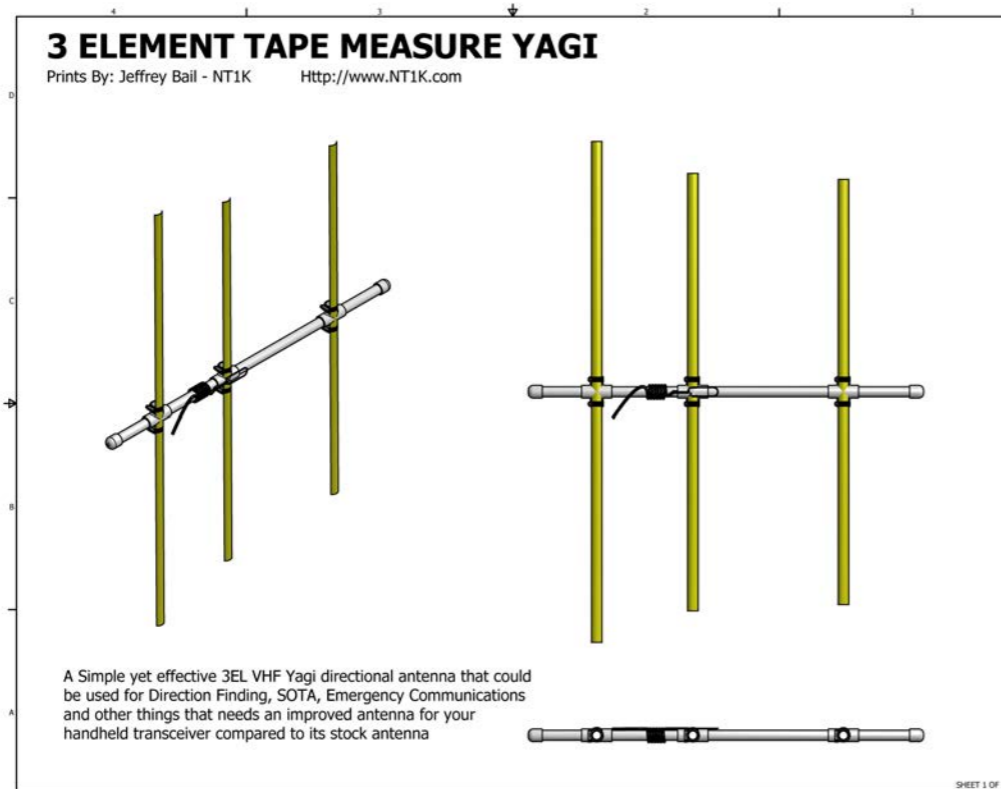

# Basic foxhunting equipment – Loop Antenna



- Directional “null” antenna
- Gain around the loop
- Null in the middle of the loop
- Peaks indicate direction of fox
- Use the null “lack of signal” when you’re close to fox for a sharp bearing
- Confirm the direction!

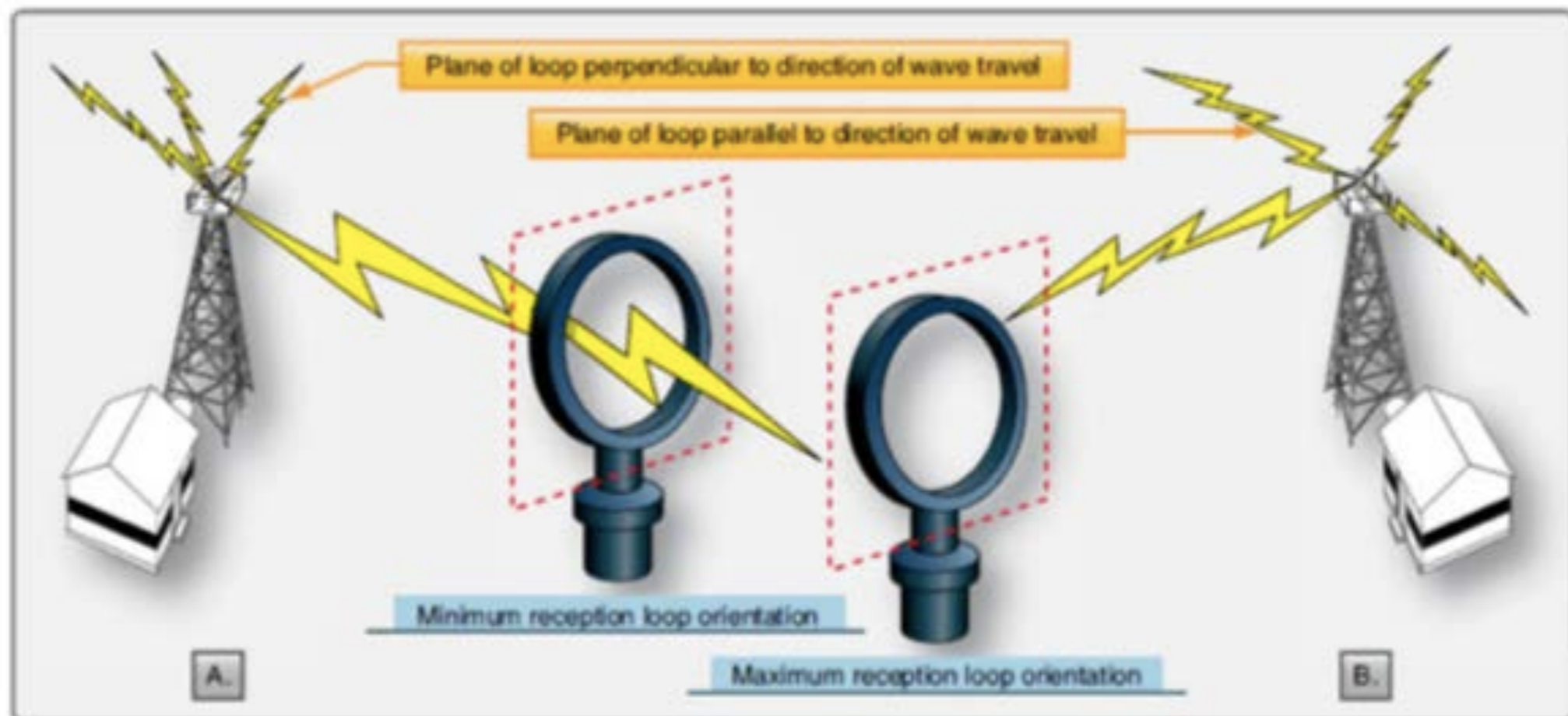

# Basic foxhunting equipment – Attenuator

When you get close to the fox, the signal will overload the receiver. Attenuation dampens the signal strength.

Body Blocking

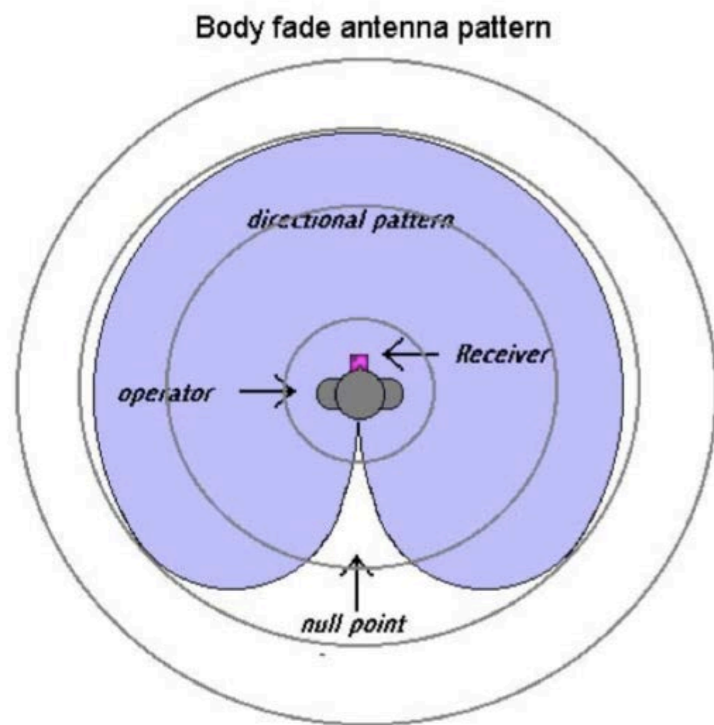

Passive / Resistor

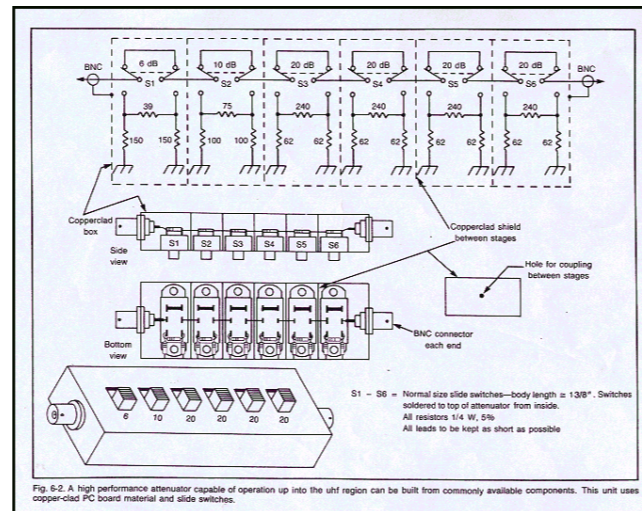

Active / Frequency

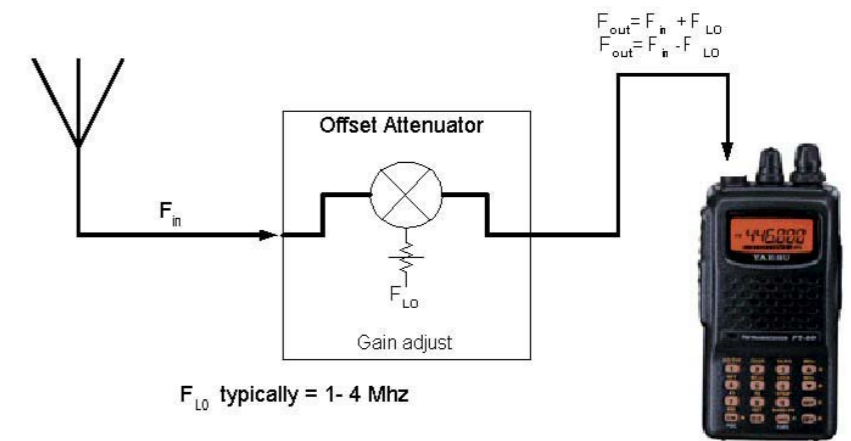

# Basic foxhunting equipment – Attenuator

## Frequency Offset Attenuator

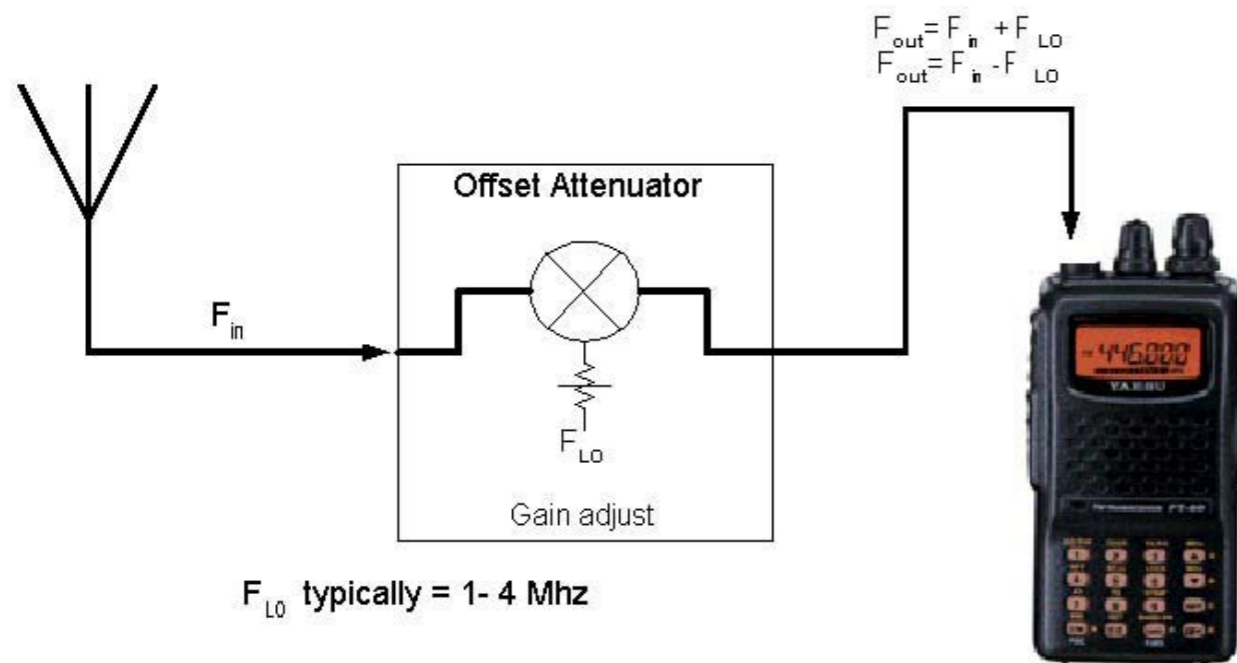

- RSSI bar graphs don't have a very good range 20-30db
- RSSI overloads easily
- RFI can get into the radio itself
- Solution: Frequency Offset Attenuator
- Basis: Going off frequency attenuates the signal

[How to Use a Frequency Offset Attenuator \(YouTube video\)](#)



- Tune your receiver 4 MHz above or below the fox frequency
- Rotate the knob all the way clockwise to add or subtract the 4 MHz back into the radio signal
- Rotate counter-clockwise to attenuate
- Offset attenuator is really a mixer

# Three step technique for finding the fox

Example: Fall 2018 FCARC Fox Hunt

1. Finding the signal



2. Triangulating the source

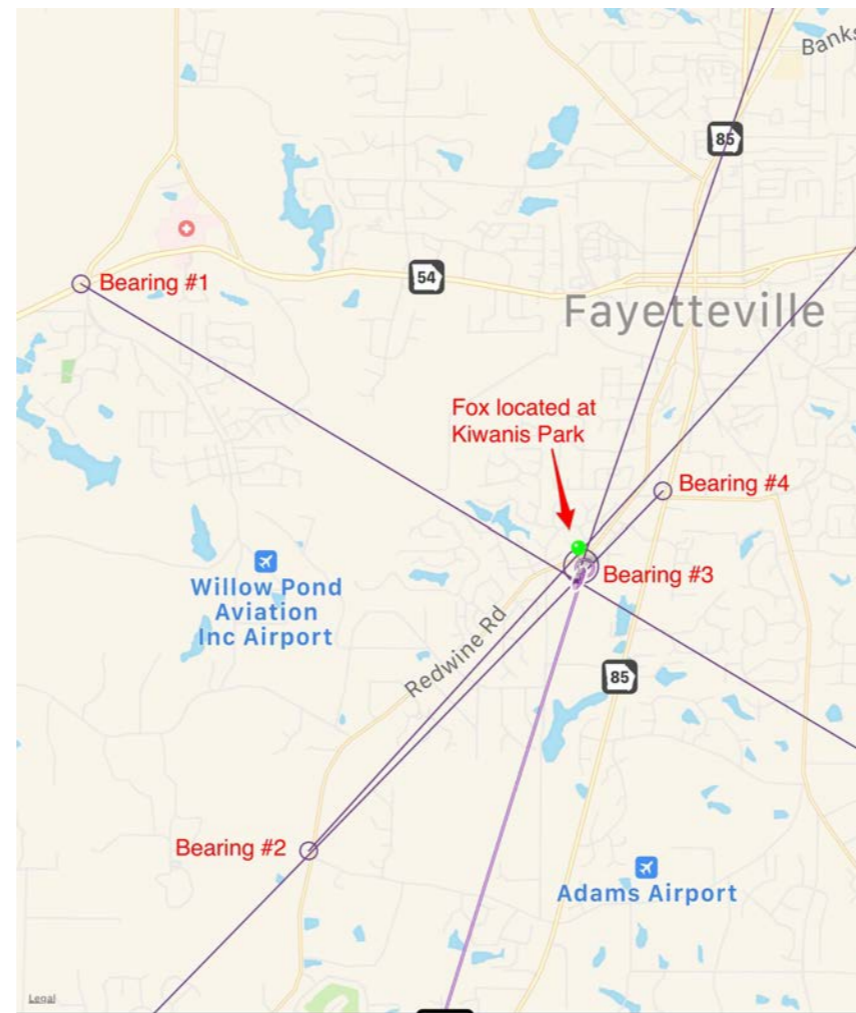

3. Attenuating & finding the fox



# Step 1 – Finding the signal

1. Study map!
2. Start from high ground
3. Get a good first signal
4. Pay attention to signal strength
5. Look for reflected signals
6. Plot the first bearing

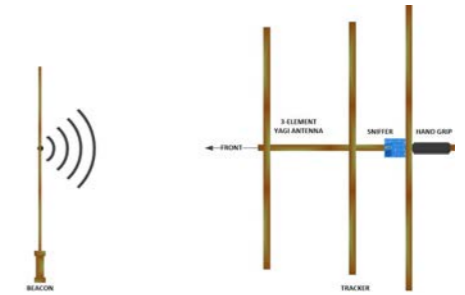

[How to Take a Bearing](#)  
[\(YouTube video\)](#)

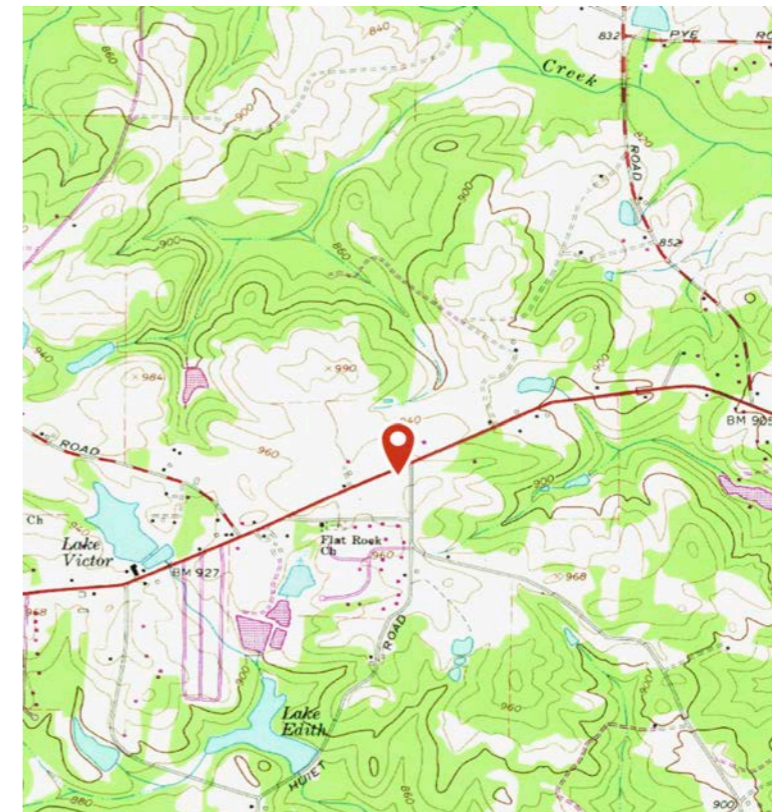



# Step 2 – Triangulating the source

1. Take multiple bearings to the direction of the strongest fox signal
2. Need at least two bearings to get an intersection, but better to get three
3. Resist the temptation to go directly to the source of a single bearing
4. Consider signal strength and reflections
5. Plot the bearings on a map or use an app (Fox Hunt Pro)
6. Triangulating is best used when the fox is far away
7. Triangulating is not as useful once you are close to the fox and the signal is strong in all directions

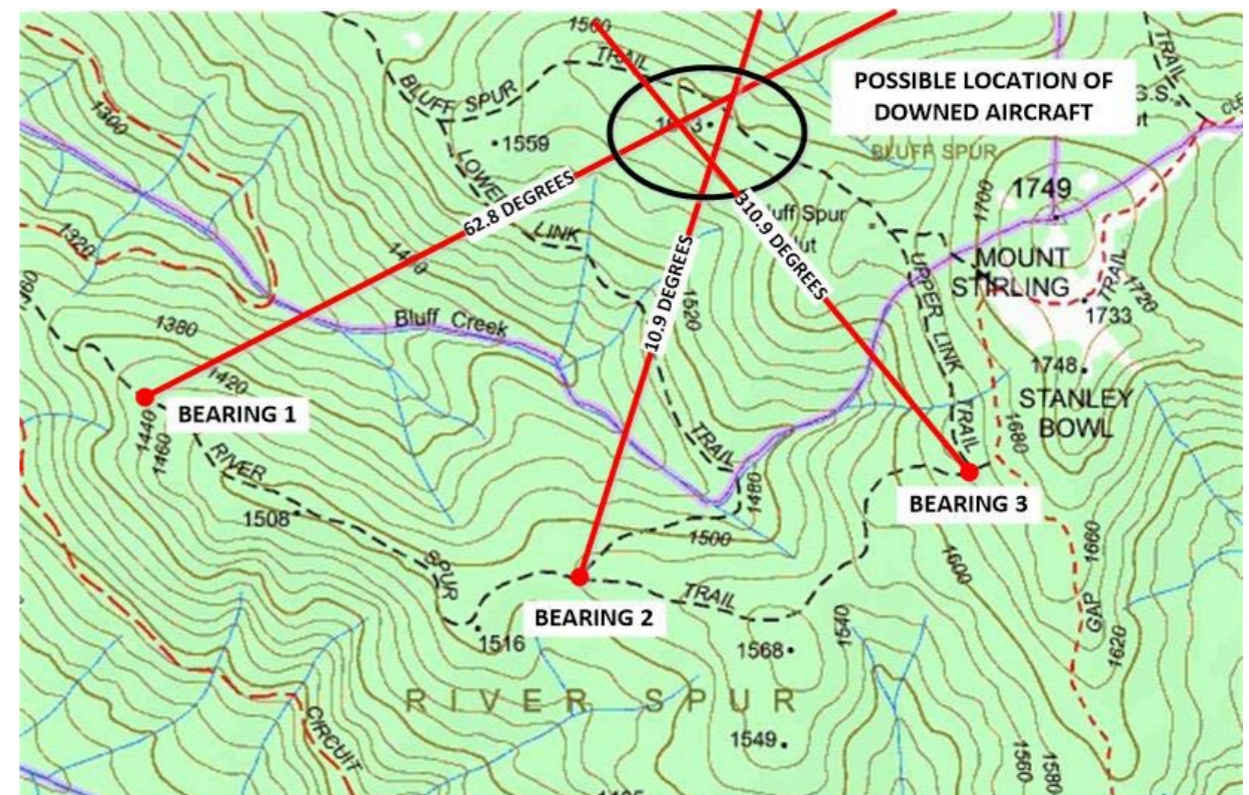

# Step 2 – Triangulating the source (Example 1)

AMRC Fox Hunt – 4/7/2018

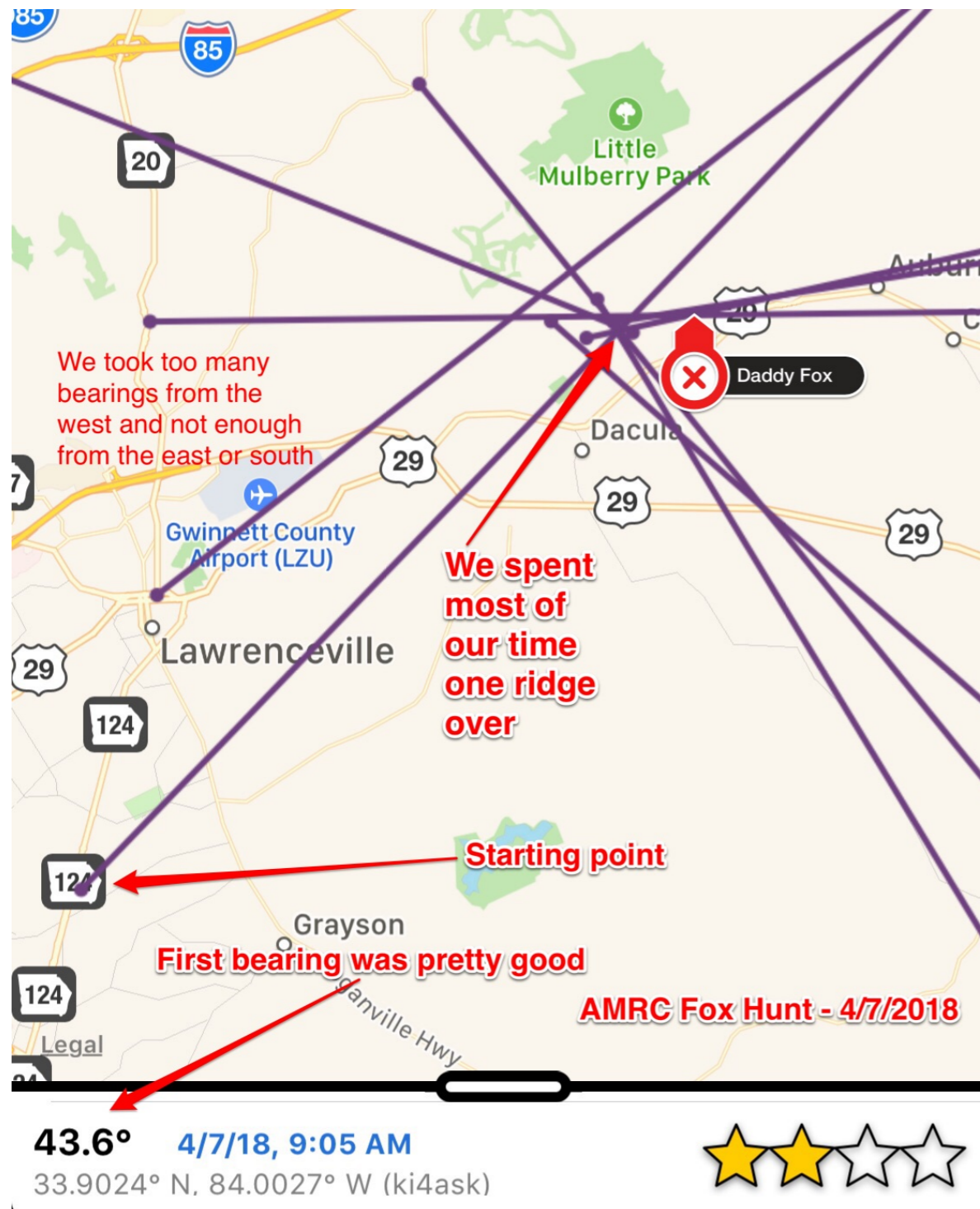

- Alford Memorial Radio Club (Stone Mtn)
- Daddy fox on VHF – 20 miles away
- Baby fox on UHF – walking distance
- 3 hours to find the foxes
- Not sure if anyone found daddy fox
- Most all teams found baby fox
- Very hilly terrain
- Lots of reflected signals



# Step 2 – Triangulating the source (Example 2)

FCARC Fox Hunt – 9/22/2018

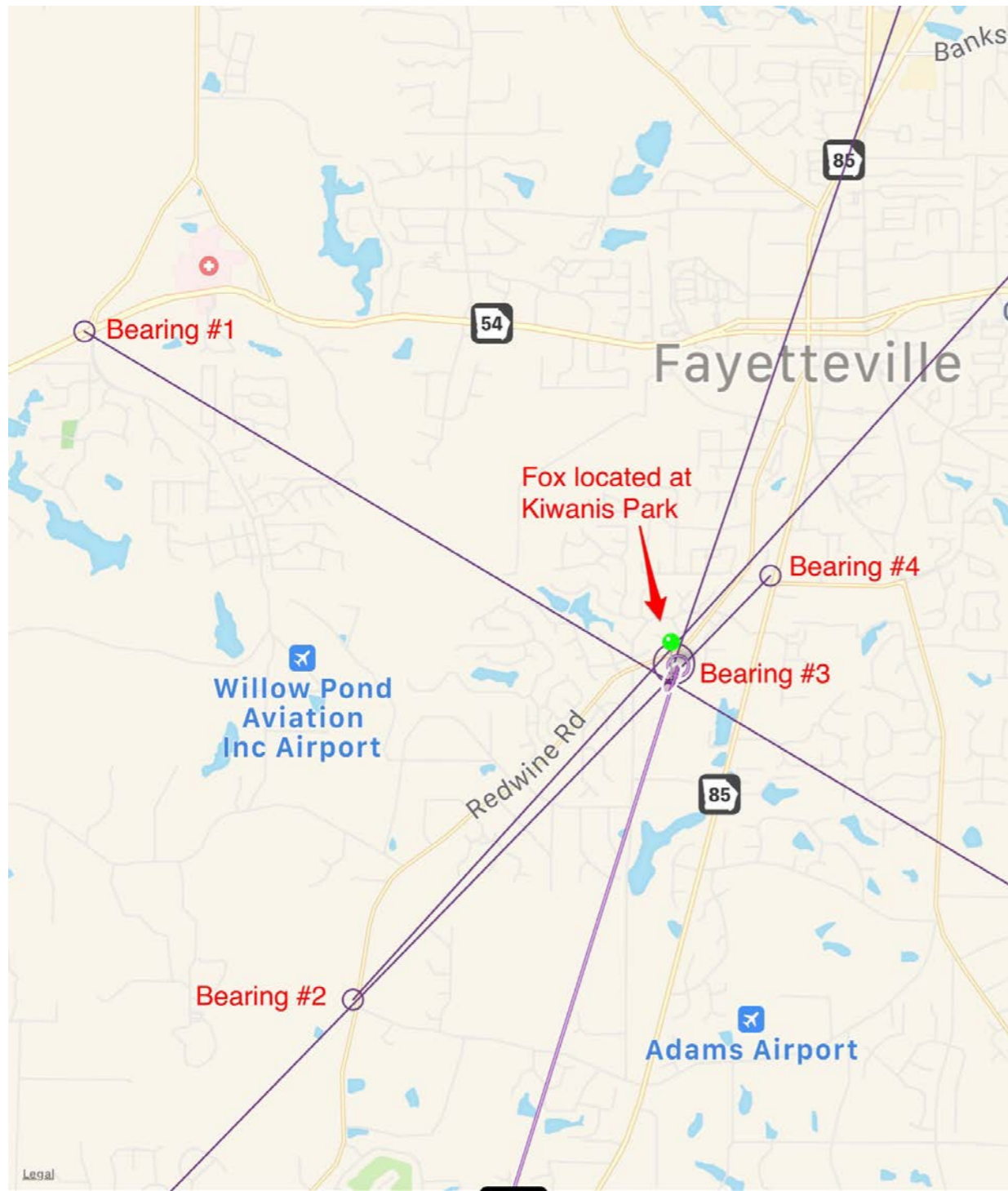

- Fayette County Amateur Radio Club
- Baby fox on VHF – audio & tones
- Started on high ground
- Got a solid first & second bearing
- Actually took 3<sup>rd</sup> bearing right next to the fox and didn't know it!
- Drove away and came back to bearing #3 and were first to find the fox!



# Step 3 – Attenuating the signal & finding the fox

1. If you're getting a strong signal no matter where you point the antenna, you're close
2. If you can take the antenna off the radio and you get a strong signal, you're close
3. When you're close you've got to attenuate the signal
4. Consider using a loop and/or an attenuator to dampen the signal
5. Use body blocking to help as well



# General fox hunting tips

1. Fox hunting involves following clues – signal strength, direction, terrain, visual clues
2. Read the terrain and know how to use it
3. Be familiar with your equipment and it's limitations
4. Bearings are rarely more accurate than 20 degrees, so the more bearings the better
5. Discard bearings that don't make sense
6. VHF is mostly line of sight, but there can be reflections and multi-path signals
7. The last few hundred feet of the hunt are often the hardest
8. Use your eyes! Your eyes work faster than your radio equipment when you're close
9. Have fun!



# Advanced topics

- History of radio direction findings
- Map, compass, and land navigation skills
- Doppler shift systems
- TDOA systems
- Radio orienteering
- Attenuator circuits
- Antenna theory
- Competitive ARDF

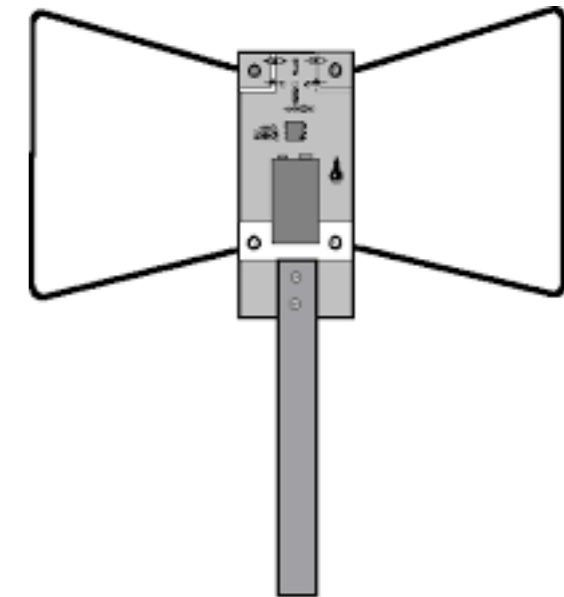
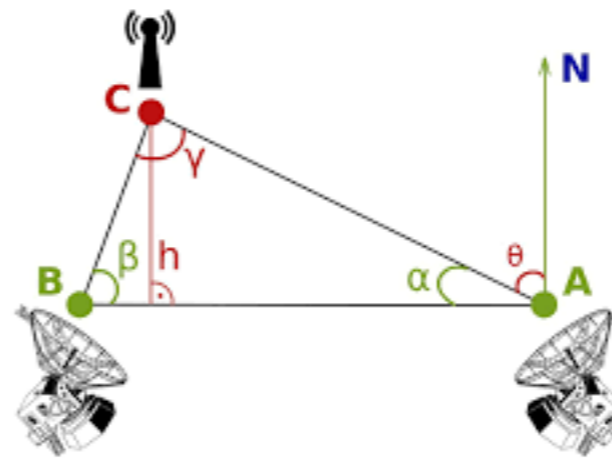
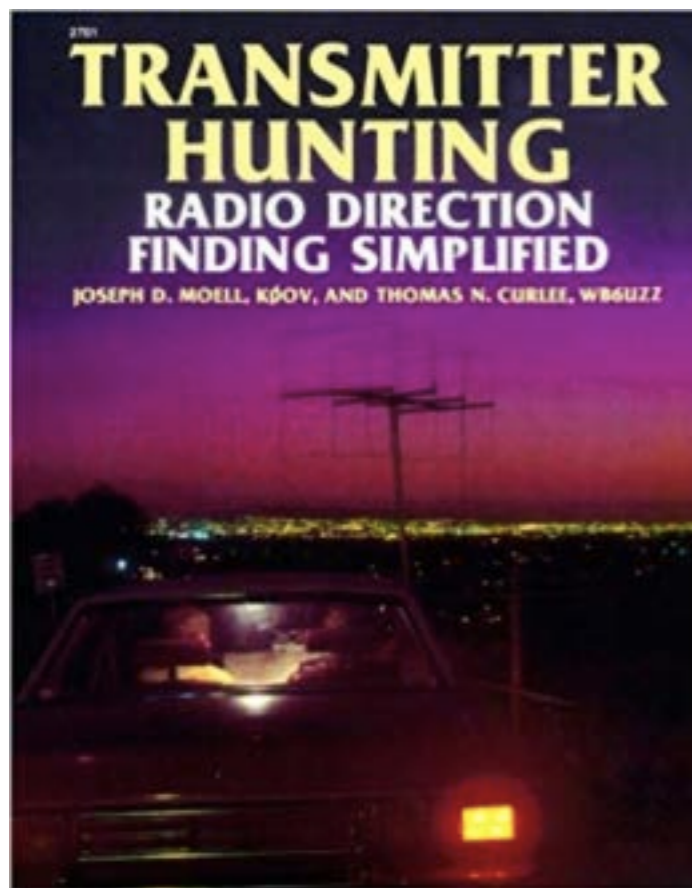

Fig. 1 - The assembled TDOA antenna unit - coaxial cable to receive runs behind the PCB and through the PVC pipe handle.



# Suggested resources

1. *Transmitter Hunting: Radio Direction Finding Simplified*  
by: By Joseph D. Moell, KØOV, and Thomas N. Curlee, WB6UZZ
2. <http://homingin.com> - the definitive website about fox hunting
3. Byonics – manufacturer of "fox" transmitters
4. Arrow Antennas – manufacturer of "fox" hunting antennas and gear
5. CQ Amateur Radio magazine – regularly has fox hunting articles and ARDF info
6. Local amateur radio clubs – websites and Facebook pages



# About the speaker – Joe Domaleski, KI4ASK

- Husband, father, business owner, and donut connoisseur
- Lifelong radio aficionado
- Amateur Extra class license KI4ASK
- GMRS license WRCL957
- ARRL Assistant Section Manager for Georgia Section
- Past-president of the Fayette County Amateur Radio Club
- Volunteer Examiner – ARRL VE, Laurel VEC, W5YI-VEC, W4VEC, GLAARG
- Member of ARRL, ARES, and AMSAT #41409
- Enjoys public service – Special events, EmComm, Skywarn, CERT, ARES, AUXC
- Enjoys mobile operations – QRP, SOTA, Fox hunting, and (of course) AMSAT
- Married to KI4HHI

